

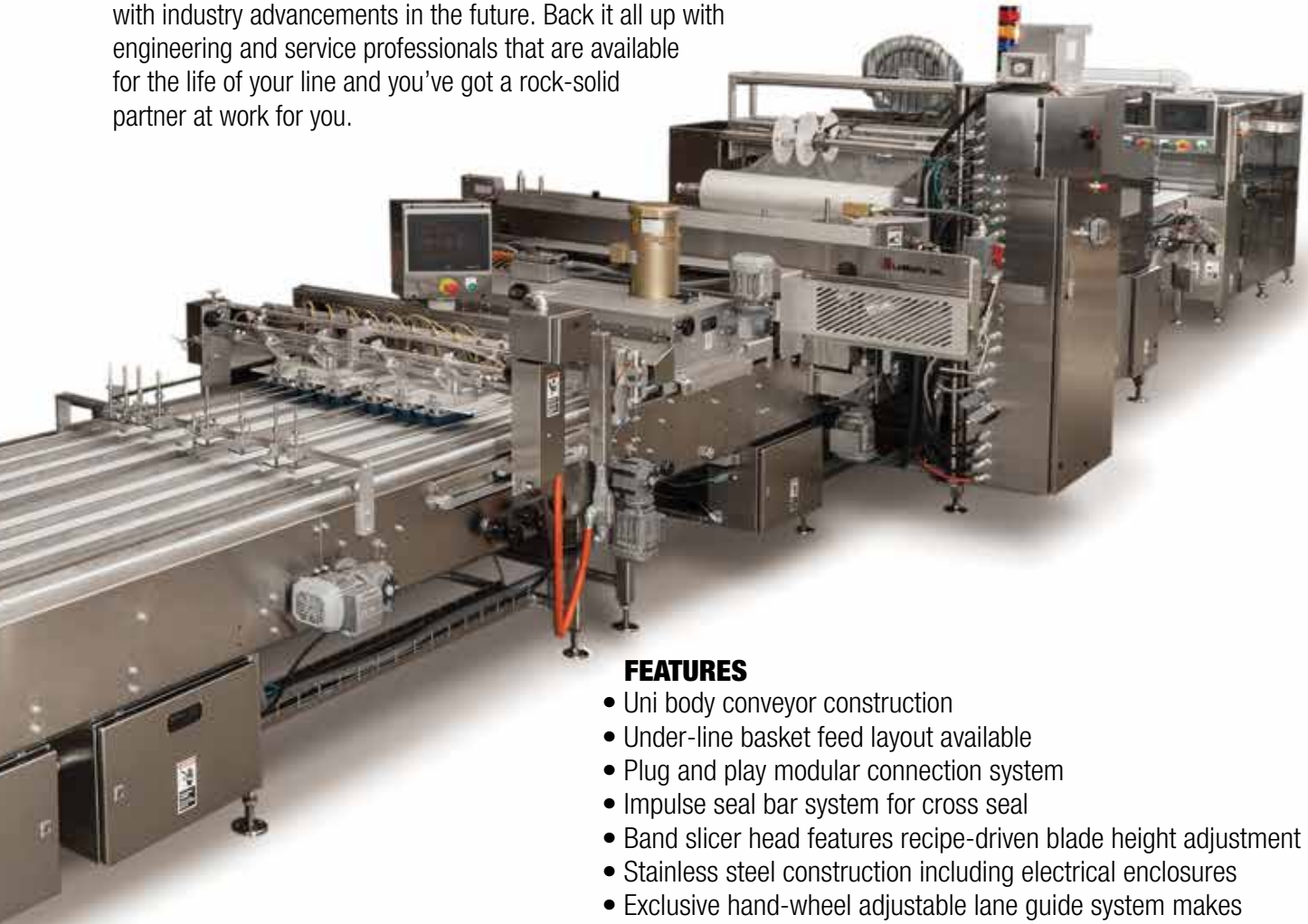

**LeMatic**  
*Cooler to the door*

# LS133 Bulk Packaging System

24 hours a day, seven days a week, over 350 LeMatic Bulk Packers installed in bakeries around the world each process up to 1000 buns per minute. That's pretty impressive, especially when you take into account that LeMatic's Bulk Packers also set the standard for flexibility and efficiency, with less down time and better ease of maintenance. And we work smart – designing lines that can be effectively retrofitted with industry advancements in the future. Back it all up with engineering and service professionals that are available for the life of your line and you've got a rock-solid partner at work for you.



*LS133 shown with optional Hinge Slicer and Band Slicer and Tray Loader*

## **FEATURES**

- Uni body conveyor construction
- Under-line basket feed layout available
- Plug and play modular connection system
- Impulse seal bar system for cross seal
- Band slicer head features recipe-driven blade height adjustment
- Stainless steel construction including electrical enclosures
- Exclusive hand-wheel adjustable lane guide system makes changeover quick and easy
- Advanced microprocessor control
- Advanced timing and control abilities are available to service or maintenance personnel via password-protected control software
- Pull-out and removable sealing bar assembly for ease of maintenance
- Timing belt drive system
- Design emphasizes safety and reliability, straight-forward operation and complete accessibility for maintenance and sanitation
- Servo film feed for greater reliability and precision
- On-machine control panel is hinged to allow access for maintenance

# LS133 Bulk Packaging System



Seal bar design offers precise heat control and fast impulse sealing technology. Narrower transfer allows for running smaller product across the bar.



Pneumatic film spindles expand to hold the film in place without damaging the cardboard core and allow for plastic cores.

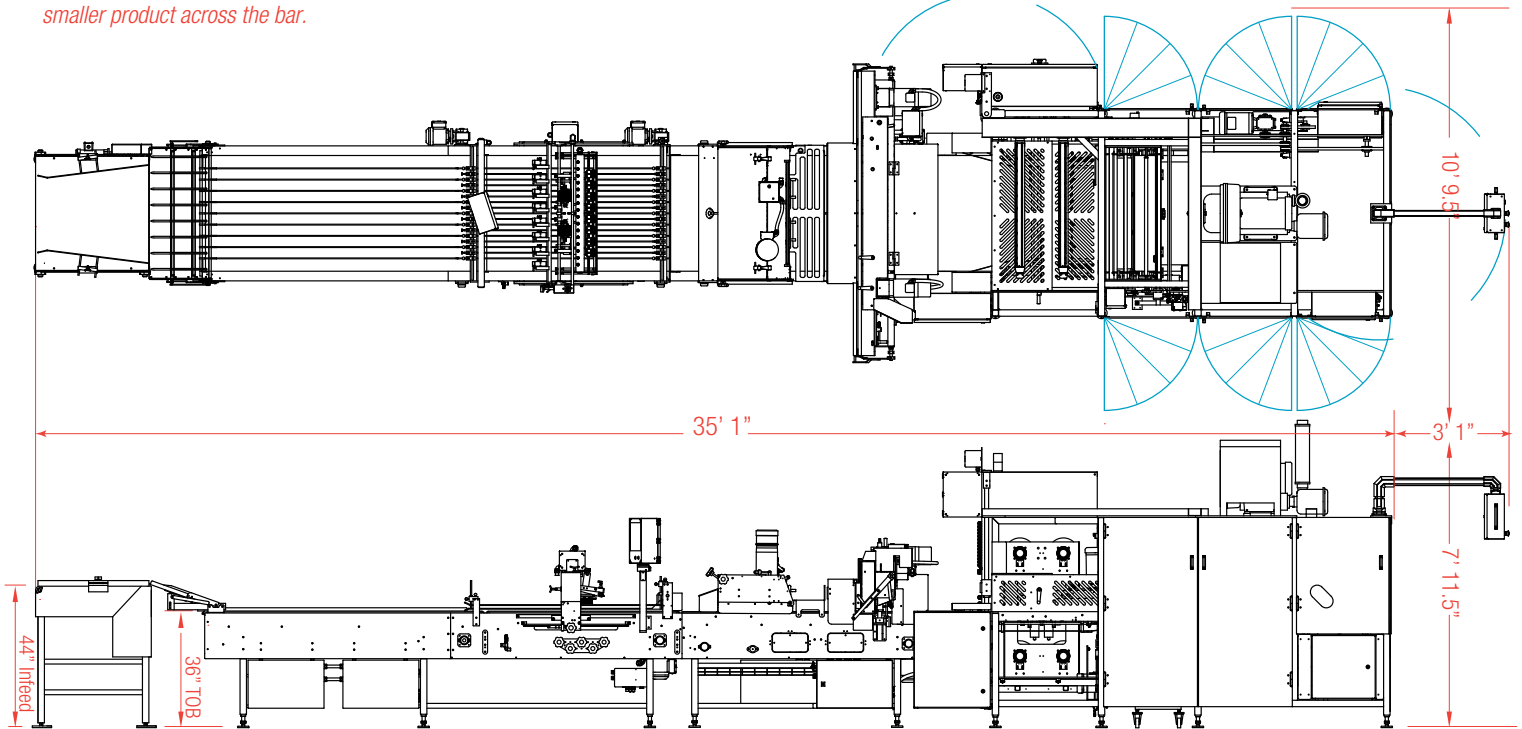

## GENERAL SPECIFICATIONS:

- Production Rate: Maximum of 35 packages per minute @ 20" long package
- Package Size: Maximum: 28"W, 27"L, 3 1/2 H, Minimum: 15"W, 8"L, 1"H
- Film Width: Maximum 34", minimum 18"
- Electrical: All standard voltages
- Air Requirements: 24 CFM [680 L/M] @90 PSI [6.2bar]
- Air Connection: 3/4" NPT

## OPTIONS:

- Single center seal
- Center seal and cut
- Mid-seals make 3 packages
- 10 or 12 product lanes (8 lanes standard)
- Hinge, web, single band, double band, and top slicing heads
- Automatic lane guides
- UL, CUL/CSA, CE compliance